



GAI-TRONICS®
A HUBBELL COMPANY

ICS Subset Extension Cable Assembly Replacement Kit

MODELS 12587-101 & 12587-102

Confidentiality Notice

This manual is provided solely as an operational, installation, and maintenance guide and contains sensitive business and technical information that is confidential and proprietary to GAI-Tronics. GAI-Tronics retains all intellectual property and other rights in or to the information contained herein, and such information may only be used in connection with the operation of your GAI-Tronics product or system. This manual may not be disclosed in any form, in whole or in part, directly or indirectly, to any third party.

General Information

The Model 12587-101 and 12587-102 ICS Subset Extension Cables allow the ICS remote subset to be positioned up to 100 feet from the remote amplifier. Model 12587-101 Extension Cable allows the interconnection of multiple cable assemblies for additional length. Model 12587-102 includes a stainless steel wall plate to allow for a wall receptacle installation. Both cable assemblies are compatible with all ICS Page/Party® remote subsets.

The Model 12587-101 consists of the following:

Qty	Description
1	Cable, 25-foot, 25-conductor, PVC jack cable with molded DB25 connectors on each end
2	4-40 male/female hex jack screws

The Model 12587-102 includes the following components:

Qty	Description
1	Cable, 25-foot, 25-conductor, PVC jack cable with molded DB25 connectors on each end
1	Wall plate, stainless steel with DB25 opening
2	Wall plate attachment screws
2	4-40 male/female hex jack screws

Installation as a Wall Receptacle

1. Arrange the cable so that the DB25 male connector is located at the amplifier enclosure and the cable's DB25 female connector is located at the wall receptacle. Remove the thumb screws from the female DB25 connector. See Figure 1.
2. Route the 25-foot cable/plug assembly inside the wall from the amplifier location to the desired wall receptacle location, and mount it by using a single gang wall plate mounting bracket (such as L-Com WPMB1). Make the connection in accordance with the appropriate electrical code.
3. Install the DB25 female connector on the supplied wall plate, using the included two 4-40 jack screws to attach the connector to the wall plate.

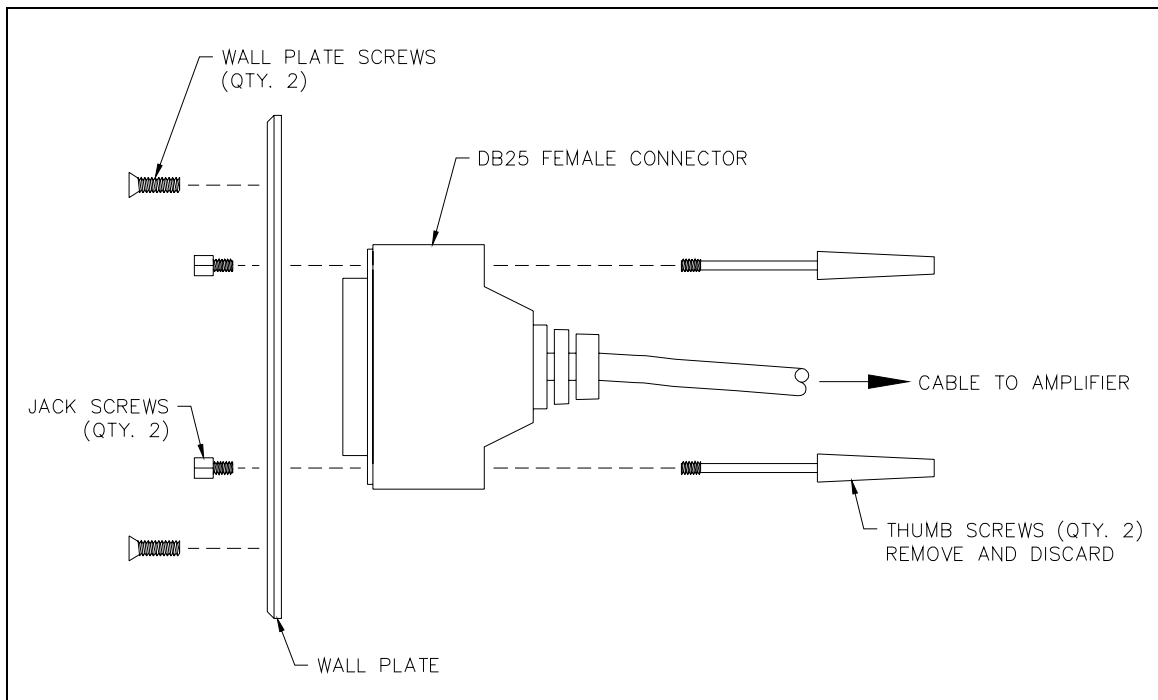

Figure 1. Installation as a Wall Receptacle

4. Install the wall plate using the two mounting screws provided.
5. After all connections have been made, plug the DB25 male connector into the receptacle at the amplifier enclosure.
6. Plug the subset plug into the DB25 wall receptacle. Be sure that the connector housing seats fully into place, and use the DB25 connector thumb screws to secure the connector.

Installation as a Subset Extension Cord

1. Arrange the extension cable so that the DB25 male connector is connected at the amplifier enclosure or wall receptacle. Remove the thumb screws from the DB25 female connector. Install the two jack screws provided. See Figure 2.
2. Plug the cable's female DB25 connector into the remote subset cable's (or an additional extension cable's) DB25 male connector and secure the connectors. Additional extension cables may be connected in order to attain the necessary length. The maximum total length of the combined extension cables is 100 feet.
3. When a cable is of sufficient length to reach the subset has been assembled, connect the female DB25 connector at the end of the cable to the receptacle on the remote subset.

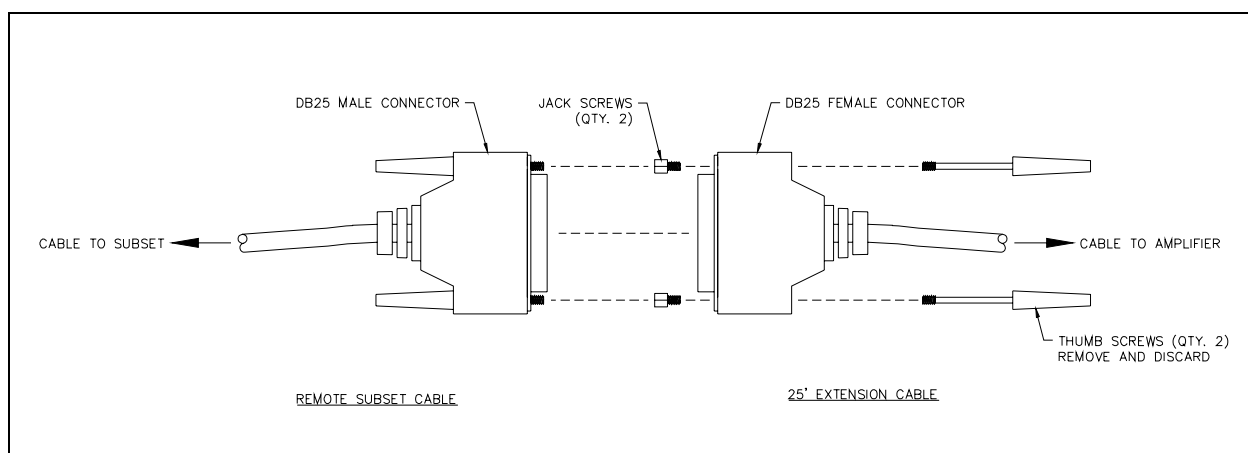

Figure 2. Installation as a Subset Extension

Warranty

Equipment. GAI-Tronics warrants for a period of one (1) year from the date of shipment, that any GAI-Tronics equipment supplied hereunder shall be free of defects in material and workmanship, shall comply with the then-current product specifications and product literature, and if applicable, shall be fit for the purpose specified in the agreed-upon quotation or proposal document. If (a) Seller's goods prove to be defective in workmanship and/or material under normal and proper usage, or unfit for the purpose specified and agreed upon, and (b) Buyer's claim is made within the warranty period set forth above, Buyer may return such goods to GAI-Tronics' nearest depot repair facility, freight prepaid, at which time they will be repaired or replaced, at Seller's option, without charge to Buyer. Repair or replacement shall be Buyer's sole and exclusive remedy. The warranty period on any repaired or replacement equipment shall be the greater of the ninety (90) day repair warranty or one (1) year from the date the original equipment was shipped. In no event shall GAI-Tronics warranty obligations with respect to equipment exceed 100% of the total cost of the equipment supplied hereunder. Buyer may also be entitled to the manufacturer's warranty on any third-party goods supplied by GAI-Tronics hereunder. The applicability of any such third-party warranty will be determined by GAI-Tronics.

Services. Any services GAI-Tronics provides hereunder, whether directly or through subcontractors, shall be performed in accordance with the standard of care with which such services are normally provided in the industry. If the services fail to meet the applicable industry standard, GAI-Tronics will re-perform such services at no cost to buyer to correct said deficiency to Company's satisfaction provided any and all issues are identified prior to the demobilization of the Contractor's personnel from the work site. Re-performance of services shall be Buyer's sole and exclusive remedy, and in no event shall GAI-Tronics warranty obligations with respect to services exceed 100% of the total cost of the services provided hereunder.

Warranty Periods. Every claim by Buyer alleging a defect in the goods and/or services provided hereunder shall be deemed waived unless such claim is made in writing within the applicable warranty periods as set forth above. Provided, however, that if the defect complained of is latent and not discoverable within the above warranty periods, every claim arising on account of such latent defect shall be deemed waived unless it is made in writing within a reasonable time after such latent defect is or should have been discovered by Buyer.

Limitations / Exclusions. The warranties herein shall not apply to, and GAI-Tronics shall not be responsible for, any damage to the goods or failure of the services supplied hereunder, to the extent caused by Buyer's neglect, failure to follow operational and maintenance procedures provided with the equipment, or the use of technicians not specifically authorized by GAI-Tronics to maintain or service the equipment. **THE WARRANTIES AND REMEDIES CONTAINED HEREIN ARE IN LIEU OF AND EXCLUDE ALL OTHER WARRANTIES AND REMEDIES, WHETHER EXPRESS OR IMPLIED BY OPERATION OF LAW OR OTHERWISE, INCLUDING ANY WARRANTIES OF MERCHANTABILITY OR FITNESS FOR A PARTICULAR PURPOSE.**

Return Policy

If the equipment requires service, contact your Regional Service Center for a return authorization number (RA#). Equipment should be shipped prepaid to GAI-Tronics with a return authorization number and a purchase order number. If the equipment is under warranty, repairs or a replacement will be made in accordance with the warranty policy set forth above. Please include a written explanation of all defects to assist our technicians in their troubleshooting efforts.

Call 800-492-1212 (inside the USA) or 610-777-1374 (outside the USA) for help identifying the Regional Service Center closest to you.